

PERFIL/PROFILE:
A30 R3

NOMBRE/NAME:
BULLNOSE-30

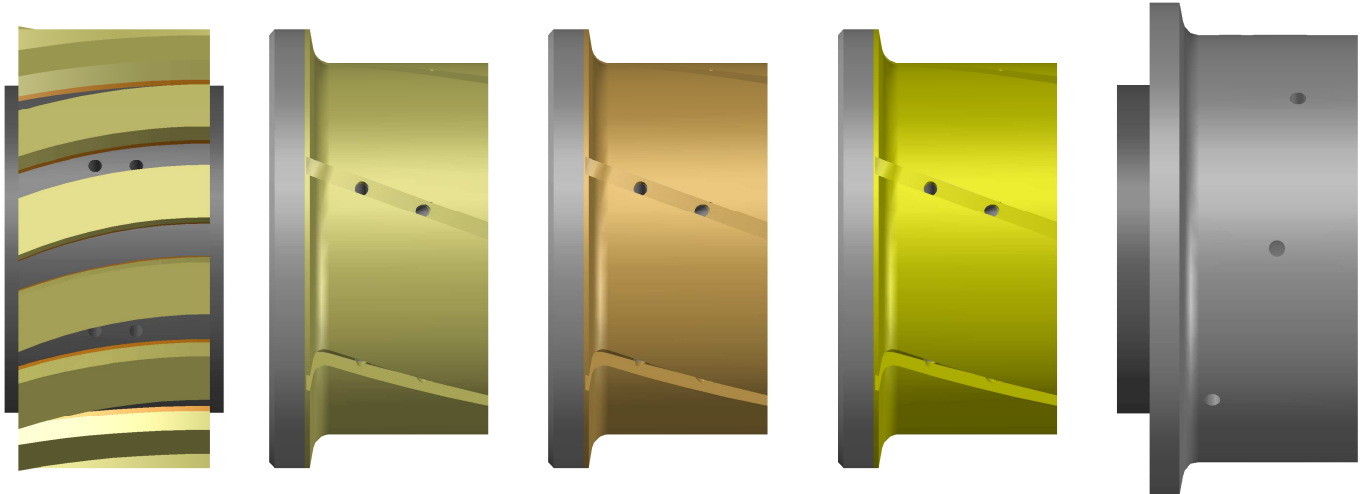
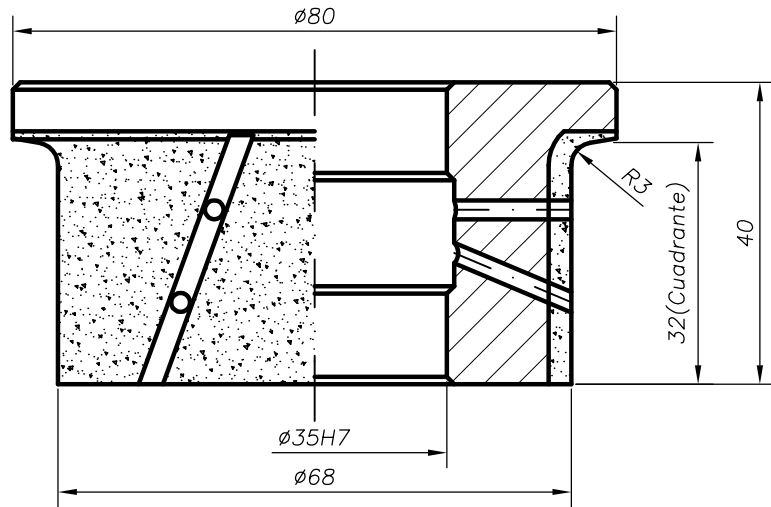
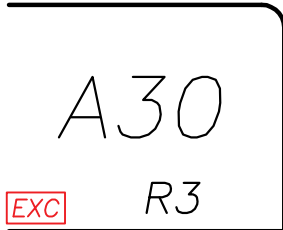

	POS.	CODIGO/CODE	DESCRIPCION/DESCRIPTION
METALICA METALLIC	1	S-743316	CNC 35 D80 ZACK (Z0 30) M P.1 SEG EXC
	2	S-740481	CNC 35 D80 ANA (A30 R3) M P.2 EXC
	3	S-740482	CNC 35 D80 ANA (A30 R3) M P.3 ECX
	4	S-740483	CNC 35 D80 ANA (A30 R3) M P.4 EXC
DIAMLOX	5	S-870212	CNC 35 D90 ANA (A30 R3) DIAMLOX 1200