

PERFIL/PROFILE:
T30 R3

NOMBRE/NAME:
DOUBLE RADIUS-30

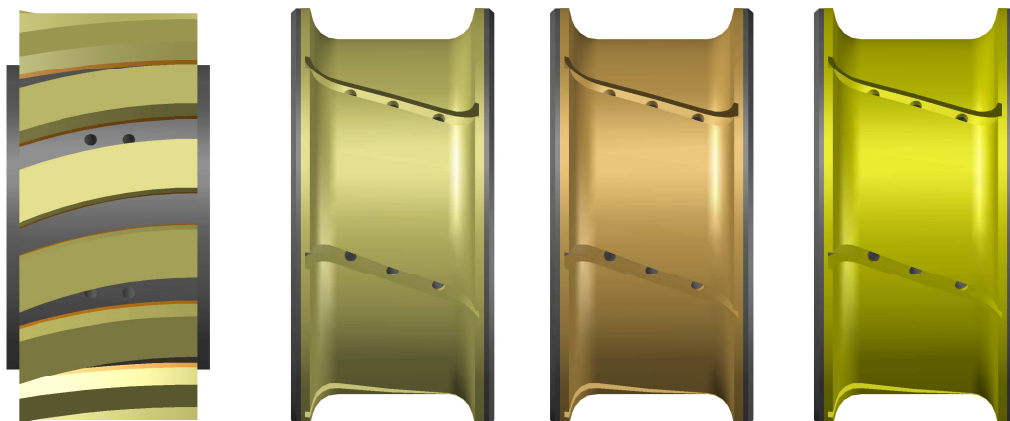
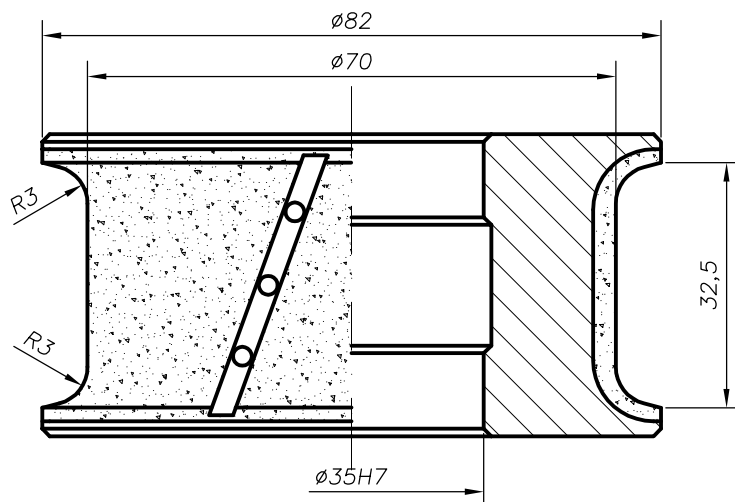

	POS.	CODE	DESCRIPTION
METALLIC	1	S-743316	CNC 35 D80 ZACK (Z0 30) M P.1 SEG-A EXC SIL
	2	S-743440	CNC 35 D82 TESSA (T30 R3) M P.2 EXC SIL
	3	S-743441	CNC 35 D82 TESSA (T30 R3) M P.3 EXC SIL
	4	S-743422	CNC 35 D82 TESSA (T30 R3) M P.4 EXC SIL