

PERFIL/PROFILE:
F30 R15

NOMBRE/NAME:
OGEE-30

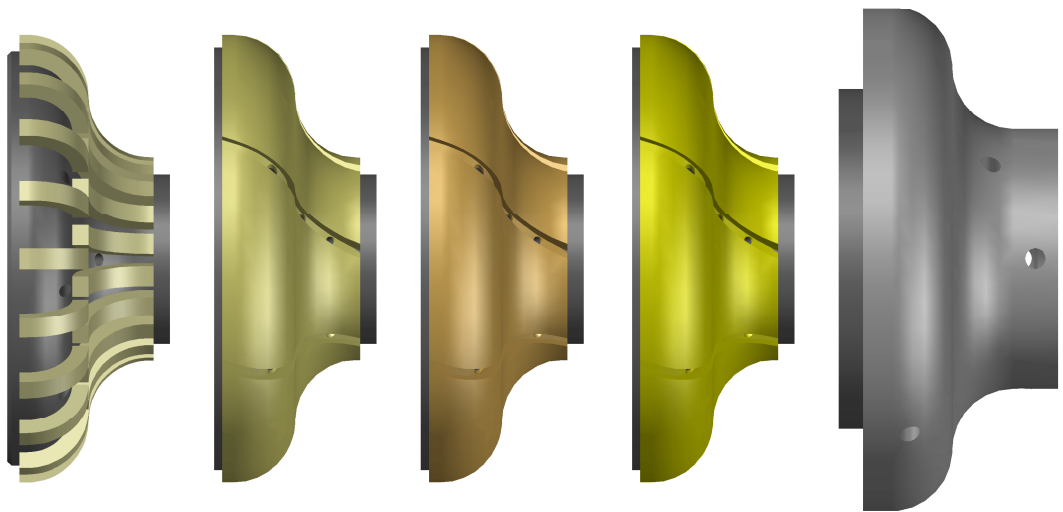
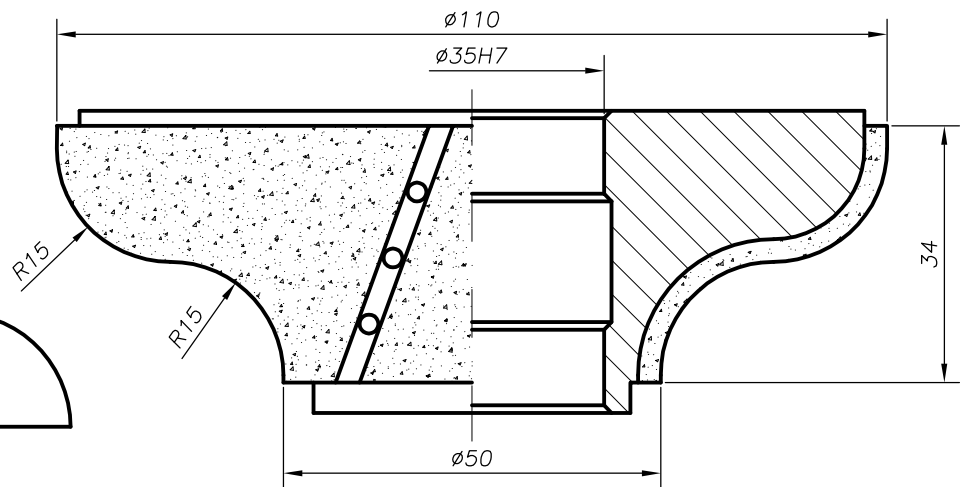
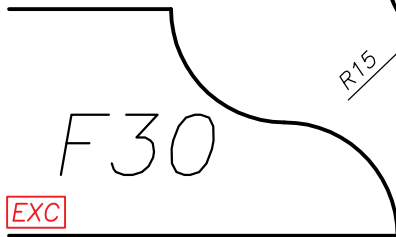

| | POS. | CODIGO/CODE | DESCRIPCION/DESCRIPTION |
|-----------------------|------|-------------|------------------------------------|
| METÁLICA/ METALLIC | 1 | S-743176 | CNC 35 D110 (F30 R15) M P1 SEG EXC |
| | 2 | S-743189 | CNC 35 D110 (F30 R15) M P2 EXC |
| | 3 | S-743190 | CNC 35 D110 (F30 R15) M P3 EXC |
| | 4 | S-743187 | CNC 35 D110 (F30 R15) M P4 EXC |
| DIAMLOX | 5 | S-870301 | CNC 35 D124 (F30 R15) DIAMLOX 1200 |