

PERFIL/PROFILE:
F30 R15

NOMBRE/NAME:
OGEE-30

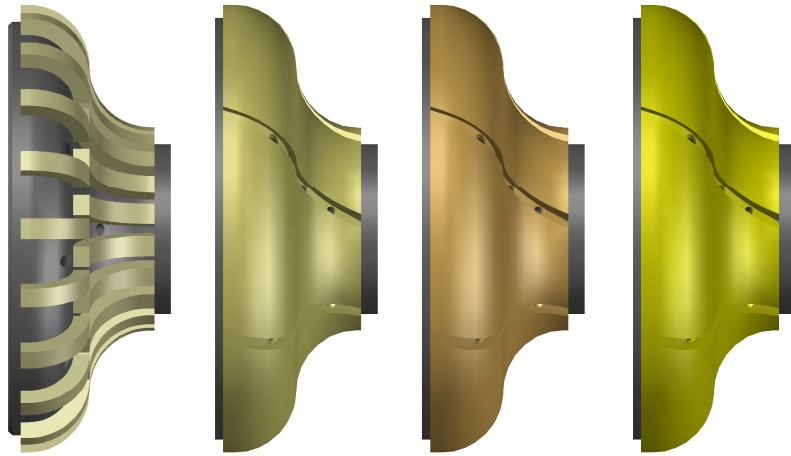
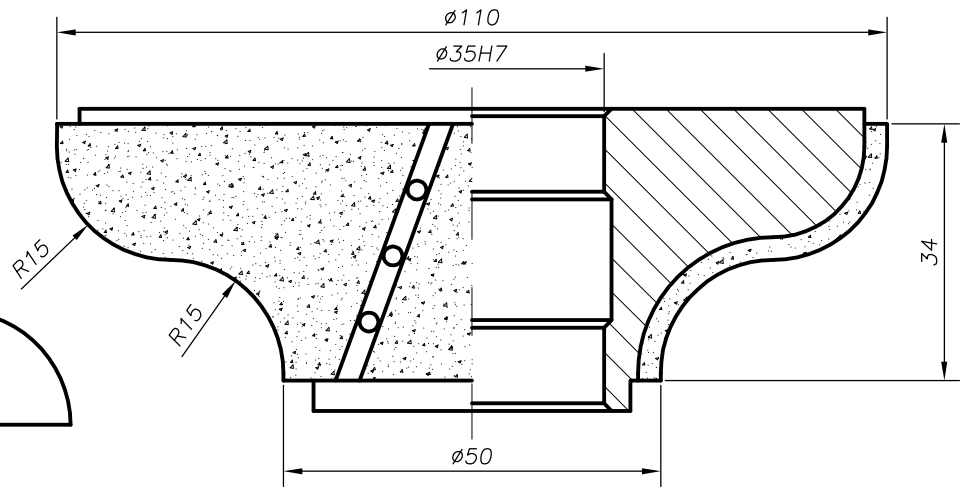
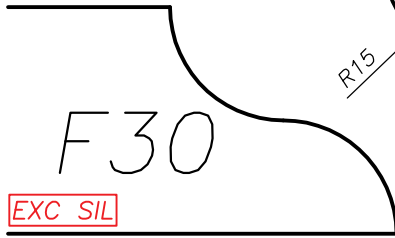

	POS.	CODIGO/CODE	DESCRIPCION/DESCRIPTION
METÁLICA/ METALLIC	1	S-743176	CNC 35 D110 (F30 R15) M P1 SEG EXC SIL
	2	S-743189	CNC 35 D110 (F30 R15) M P2 EXC SIL
	3	S-743190	CNC 35 D110 (F30 R15) M P3 EXC SIL
	4	S-743187	CNC 35 D110 (F30 R15) M P4 EXC SIL